

TECHNICAL FEATURES

Models	Thickness	Volume
SGB3 K5	5 mm	18 - 35 m³
SGB3 K6	6 mm	18 - 35 m³
SGB3 K8	8 mm	18 - 35 m³
SGB3 K10	10 mm	18 - 35 m³

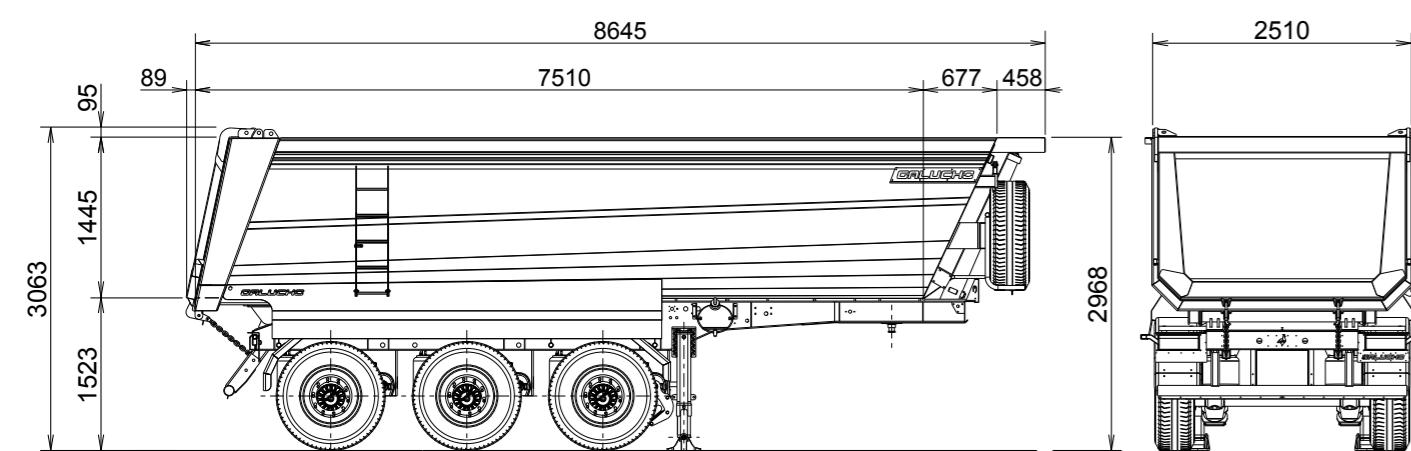

GALUCHO

Galucho is a privately held company specializing in the development of efficient solutions for its three business units: Agriculture, Transport Equipment and Spare Parts.

With 100 years, our history began in 1920 in São João das Lampas, Portugal, where Jose Francisco Justino, a young entrepreneur and our founder, specialized in the development of agricultural equipment.

Galucho rapidly grew and led the process of agriculture mechanization in Portugal and Spain. Due to their success, Galucho expanded its area of operations and dedicated itself to three main areas: agricultural equipment and transport equipment.

Currently Galucho continues to develop its activity on an international scale with production sites in Europe (Portugal) and Africa (Algeria). Our wide range of worldwide strategic partners also helps strengthen Galucho's presence as a global company.



Galucho headquarters  
São João das Lampas | Sintra | Portugal

**GALUCHO**

GALUCHO - Indústrias Metalomecânicas, S.A.  
Avenida Central, Nº4 | 2705-737 São João das Lampas | Sintra - Portugal

geral@galucho.pt

(+351) 219 608 500 (Chamada para a rede fixa nacional)

www.galucho.pt

Official distributor:



Engravings and technical data are for guidance only, subject to change without notice.



**GALUCHO**



**SGB3** / 3-AXLE SEMI-TRAILER TIPPER



**STANDARD SPECIFICATIONS**

- CAPACITY: 25m³
- THICKNESS: HARDOX450 5 MM
- 9 TON SAF AXLES
- EBS 2S-2m
- RAISABLE 1<sup>ST</sup> AND 2<sup>ND</sup> AXLE
- GRAVITY OPERATED DOOR
- HYVA HYDRAULIC CYLINDER
- 4090 mm CHASSIS
- MANUAL TARPAULIN
- FIXED / DETACHABLE BUMPER
- 6 CONTINENTAL 385/65 R22.5 WHEELS
- CENTRAL STABILISER
- 30-LITRE WATER TANK
- TOOL BOX

**OPTIONAL FEATURES**

- HYDRAULIC DOOR
- 6, 8 OR 10-mm THICKNESS
- ELECTRIC TARPULIN
- CAPACITY: 18 - 35m³
- 10-TON BPW/SAF AXLES
- SELF-STEERING 3<sup>RD</sup> AXLE
- 4500 mm CHASSIS AND 1300 mm KINGPIN
- ASPHALT KIT (COLLAPSIBLE BUMPER, REAR TRAY, WHITE REAR LIGHT AND TAILLIGHT PROTECTION)
- LOAD PRESSURE GAUGE
- FIRE-FIGHTING CABINET
- MICHELIN TYRES
- SPEEDLINE ALUMINIUM RIMS



MANUAL TARPAULIN

THICKNESS: HARDOX450 5 mm

CAPACITY 25 m³

HYVA HYDRAULIC CYLINDER

GRAVITY OPERATED DOOR

SPARE WHEEL BRACKET

TOOL BOX

CENTRAL STABILISER

CHASSIS 4090 mm

9 TON SAF AXLES WITH RAISABLE 1<sup>ST</sup> AXLE

30-LITRE WATER TANK

6 CONTINENTAL 385/65 R22.5 WHEELS

EBS 2S-2M

FIXED / DETACHABLE BUMPER